

Contents

About this Manual	4
Edition History	4
Related Documents	5
Nomenclature	5
Trade Marks	5
Legal Disclaimer - Liability Exclusion	5
CCB-BOSSANOVA Features	6
Short Description	7
Block Diagram CCB-BOSSANOVA	11
Block Diagram CCZ-RIO	14
Top View Component Assembly CCB-BOSSANOVA	15
On-Board Connectors	16
Front Panel Connectors	17
Jumpers	17
Installing and Replacing Components	19
Before You Begin	19
Warnings	19
Caution	19
Installing the Board	20
Removing the Board	21
EMC Recommendations	22
Technical Reference - Connectors	23
Caution	23
Please Note	23
Front Panel Connectors	24
COM-A/COM-B Serial Port Connectors	25
KB/MS PS/2 Keyboard & Mouse Connector	26
Ethernet Connector	27
USB Connectors USB5/USB6	28
On-Board Connectors	29
P1 Expansion Connector LPC/USB	30
P2 Reset	32
P3 General Purpose Inputs/Outputs	32
P4 Floppy Disk Connector	33
P5 Power Connector	34
P6..P9 Cooling Fan Headers	35
P10 Power Connector	36
P11 MIDI Header	36
P12 Micro Floppy Disc Connector	37
P13/P16 Serial Port 1/2 CU-Module Header	38
P21/P22 IDE Expansion Connector & CompactFlash Mezzanine Connector	39
P23 External IDE Header	42
P24 IDE/ATA Connector for 2.5-Inch Drives	43
P30 LAN Connect I/F (LCI) Connector	44
J1/J2 Rear I/O	45
J1 Rear I/O Connector	46

J2 Rear I/O Connector	47
RS-232E Transceivers	48
Firmware Hub 2	49
Power Supply Requirements	49
Schematics	50

About this Manual

This manual is a short form description of the technical aspects of the CCB-BOSSANOVA, required for installation and system integration. It is intended for the very advanced user only.

Edition History

EKF Document	Ed.	Contents/ <i>Changes</i>	Author	Date
Text # 3580 ccb_tie.wpd	1	Technical Information CCB-BOSSANOVA English, Preliminary Edition	jj	7 September 2004
	2	Added illustration top view component assembly Changed occurrences of COM1(2) to COM-A(-B) reflecting the various assembly configurations of CC9/CCB and CD2/CCB, with mapping to COM1(2...) by BIOS setup	jj	20 October 2004
	3	Added photos	jj	25 April 2005
	4	Added photo (CCB-BOSSANOVA with front panel CF Card slot & hard disk option)	jj	18 January 2006
	5	Corrected table rear I/O connector J1 pin assignment: +5V USB now J1 C24 (was previously J1 C11 by error)	jj	19 January 2007
	6	Added photos C10 C17 C30	jj	28 November 2008

Related Documents

For a description of the CC9-SAMBA or CCD-CALYPSO CPU cards, which act as carrier boards with respect to the CCB-BOSSANOVA, please refer to the correspondent CPU user guide, available by download from http://www.ekf.de/c/ccpu/cc9/cc9_e.html and http://www.ekf.de/c/ccpu/ccd/ccd_e.html respective.

Nomenclature

Signal names used herein with an attached '#' designate active low lines.

Trade Marks

Some terms used herein are property of their respective owners, e.g.

Intel, Pentium, Celeron: ® Intel

CompactPCI: ® PICMG

Windows 98, Windows NT, Windows 2000, Windows XP: ® Microsoft

EKF does not claim this list to be complete.

Legal Disclaimer - Liability Exclusion

This manual has been edited as carefully as possible. We apologize for any potential mistake. Information provided herein is designated exclusively to the proficient user (system integrator, engineer). EKF can accept no responsibility for any damage caused by the use of this manual.

CCB-BOSSANOVA Features

Feature Summary	
Form Factor	Single size Eurocard (160x100mm ²), needs 4HP (20.3mm) additional mounting space, typically delivered as a ready to use assembly unit including the CC9-SAMBA providing a common 8HP front panel shared with the CPU board, either left (bottom) or right (on top of CPU board) mounting is permissible (specify when ordering)
LPC Super-I/O ³ (SIO2)	LPC47B27x, parallel port, 2 serial ports, floppy drive controller port, keyboard controller & mouse port, infrared port, MIDI/gameport, fan control ports, GPIOs, serial IRQs
Firmware Hub ³ (FWH2)	82802 compatible device, 8Mbit Flash, LPC interface
Ethernet ³	Intel 82562 Platform LAN Connect (PLC), 10/100Mbps Fast Ethernet (not usable with CCD-CALYPSO)
Serial Transceivers ³	ADM211 or equivalent
Front Panel Connectors ¹	<ul style="list-style-type: none"> • Mini-Din connector PS/2 keyboard & PS/2 mouse • RS-232E D-Sub COM-A port connector • RS-232E D-Sub COM-B port connector (CCB-2-BOSSANOVA) • USB5/USB6 connectors (CCB-1-BOSSANOVA) • RJ45 10/100Mbps Ethernet jack
On-Board Connectors ¹	LPC Expansion interface, LCI expansion interface, IDE/ATA 40-pin header 2.54mm, drive power, IDE/ATA 44-pin header 2.00mm (2.5-inch on-board hard disk), socket for CompactFlash mezzanine module or 1.8-inch hard disk module, floppy disk header 34-pin 2.54mm, floppy disk 26-pos. ZIF socket, floppy disk power, 2 x serial port TTL header (EKF CU-module), 2 x fan heatsink header (pulse width modulation), 2 x fan heatsink header (tachometer generator), MIDI header, GPIO, reset
Rear I/O Connectors ¹	<ul style="list-style-type: none"> • J1: IDE, PS/2 KB/MS, USB5, gameport, reset • J2: Serial1/COM-A, Serial2/COM-B, LPT, floppy disk, USB6, GPIO, IRDA, MIDI, speaker, fan
On-Board Functions	Speaker
Mass Storage Options ²	<ul style="list-style-type: none"> • Hard disk drive 2.5-inch optional on-board • Mezzanine module with 1.8-inch hard disk drive or SSD • CompactFlash mezzanine module optional on-board

¹ Not all of these connectors may be present or functional on your actual CCB-BOSSANOVA board. Assembly of these connectors is highly custom specific. Discuss your needs with EKF before ordering.

² Options may be exclusive, i.e. not necessarily concurrently present. Ask EKF for special solutions if required.

³ Silicon/function may not be present on your actual CCB-BOSSANOVA board. Assembly of components is highly custom specific. Discuss your needs with EKF before ordering.

Short Description

Available as a companion board to the CC9-SAMBA CPU card, the CCB-BOSSANOVA is provided with common legacy I/O ports. Interconnection between the CCA I/O module and the CPU carrier board is achieved by the expansion connectors, which incorporate e.g. the LPC (Low Pin Count) and LCI (LAN Connect I/F) interfaces.

As an option, the CCB-BOSSANOVA is available with a rugged on-board 2.5-inch hard disk drive (1.8-inch as a mezzanine module).

The CCB-BOSSANOVA can be attached either left or right (bottom or top) to the CPU board, and shares its front panel typically with the host CPU carrier board (8HP front panel width in total).

In addition to its front panel I/O connectors, the CCB-BOSSANOVA has been designed also for rear I/O and therefore requires a non-bussed single-slot P1/P2 backplane in addition to the CompactPCI bus. However, if front panel I/O is solely needed, the J1/J2 connectors may be omitted as an option.



CCB-2-BOSSANOVA Mounted on Top of CC9-SAMBA

The CCB-BOSSANOVA communicates to the host CPU by means of 2 expansion connectors P1 (LPC) & P30 (LCI), which incorporate the LPC, USB and LCI interfaces. The LPC (Low Pin Count) is a multiplexed ISA bus, enabling the super-I/O controller chip to emulate the legacy I/O interfaces. Among these are parallel and serial ports, the PS/2 interfaces, and last not least the classic 1.4/2.8MB floppy disk controller.

The LCI interface is a networking signal bus from the CPU board, suitable to control a 10/100Mbps Ethernet PHY on the CCB-BOSSANOVA, in addition to the Gigabit Ethernet controller on the host CPU itself.

By connecting the boards together, the hosts ATA/IDE secondary interface is also available on the CCB-BOSSANOVA. Optionally, the board can be equipped with either a CompactFlash mezzanine module, or a robust 2.5-inch hard disk drive, particularly suited for use in a rugged environment. A mezzanine module is also available which carries an 1.8-inch drive, as an alternative.

The CCB-BOSSANOVA can be mounted either on the left (bottom) side of the CPU board, or right (top) side. Specify your actual needs when ordering the unit.

In addition to front panel I/O, some of the interfaces of the CCB-BOSSANOVA are available for rear I/O across the connectors J1/P1 and J2/P2. A suitable rear I/O transition module such as the CCZ-RIO would be required in addition to gain access to the I/O ports from the systems back panel.

Several I/O functions are also directly available by on-board headers on the CCB, mainly the IDE and FD interfaces. Most of the on-board connectors are only stuffed as an option, however.

If equipped with the rear I/O connectors J1/J2, the CCB-BOSSANOVA must be inserted on a slot outside of the CompactPCI backplane. A single slot rear I/O P1/P2 backplane should be present in the system rack at the CCB reserved slot. Most EKF systems have the CPCI busprint justified to the left margin of the 19-inch rack, with the system slot (CPU slot) orientated to the right end of the backplane. Following next to the right side, the CCB-BOSSANOVA should be placed in between the remaining free mounting space.



CCB-BOSSANOVA on Top of CCD-CALYPSO



Same as Above, w C15-DON USB Stick

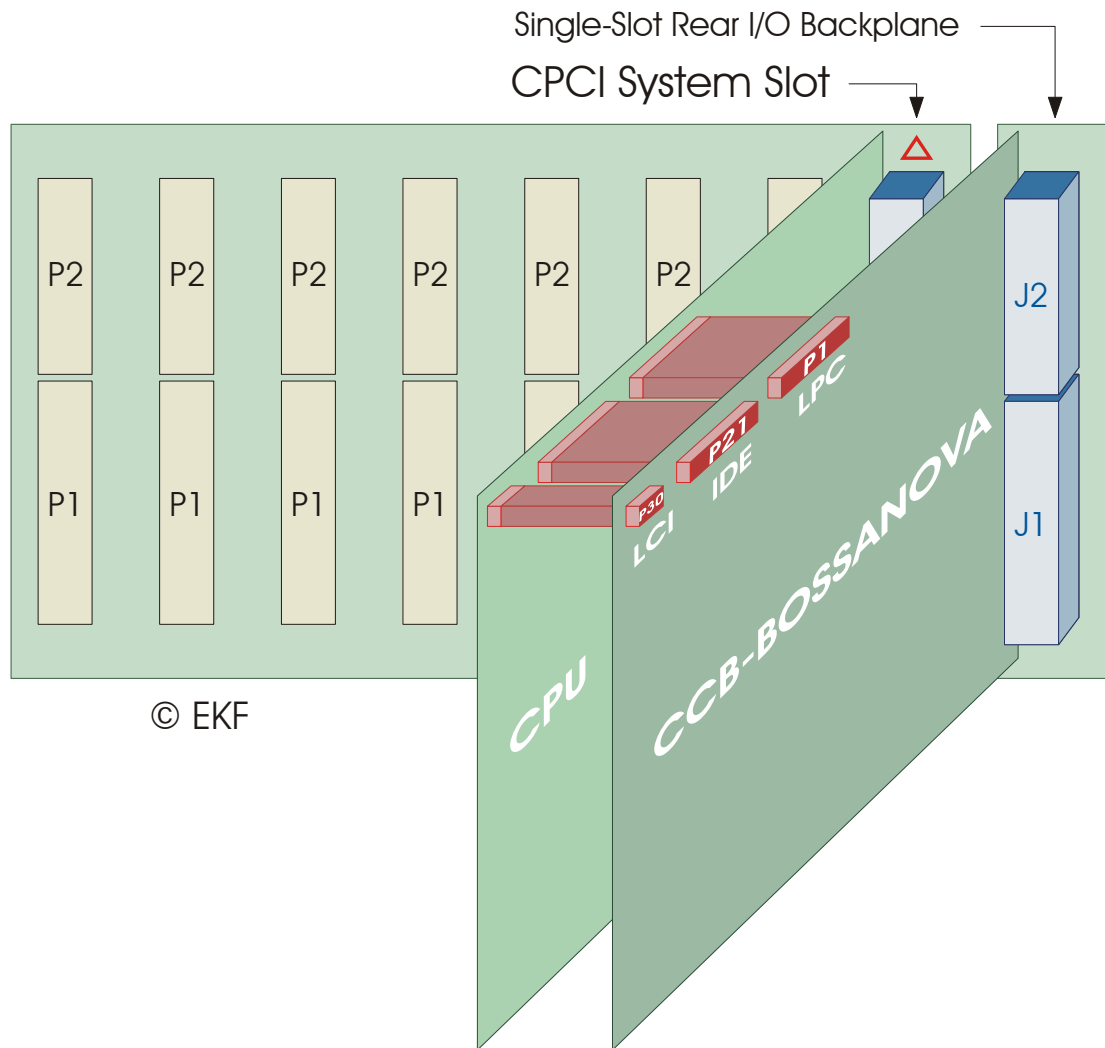

CCB-BOSSANOVA mounted on top of the CPU carrier board

Block Diagram CCB-BOSSANOVA

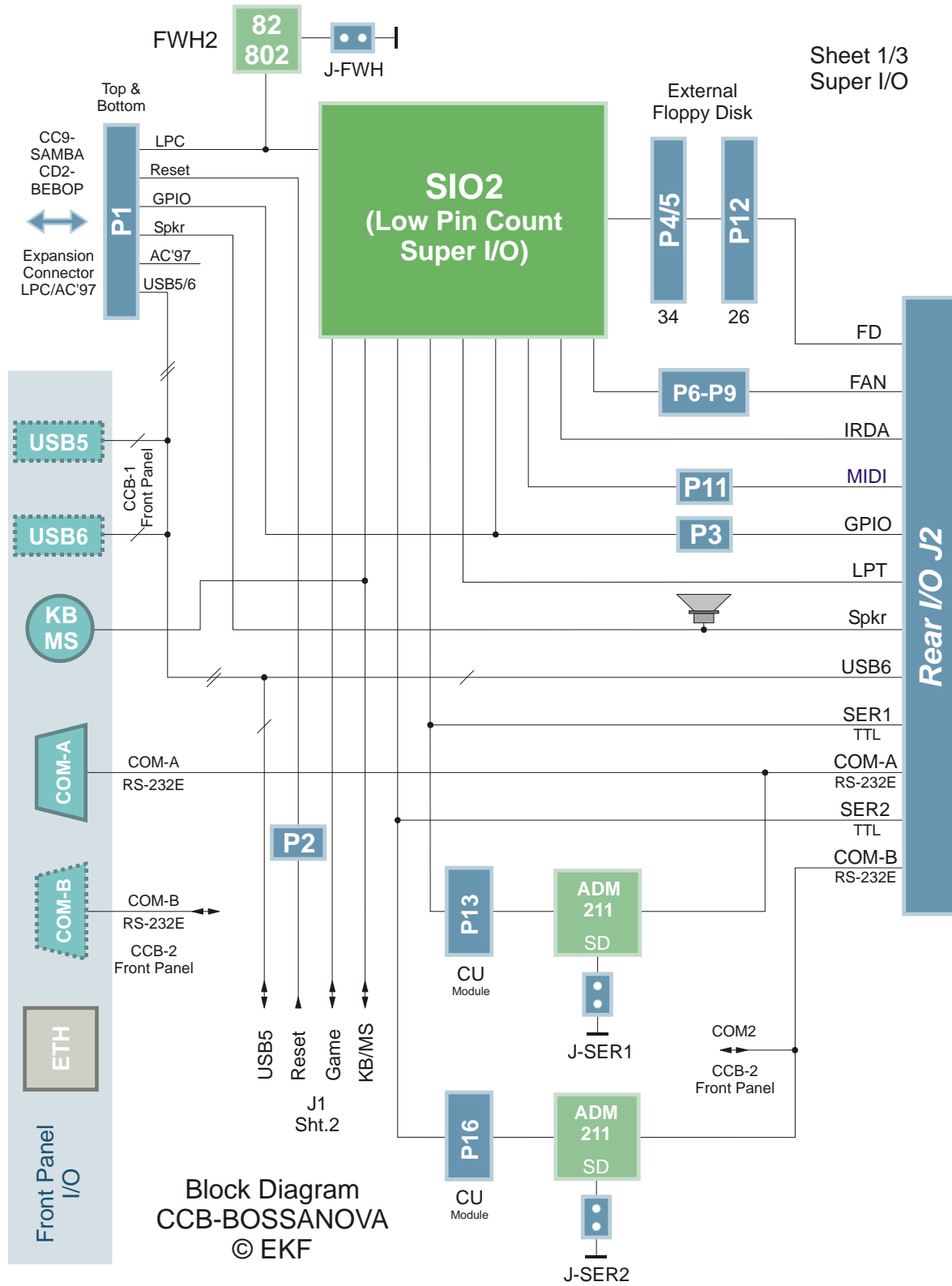

Sheet 1/3
Super I/O

Block Diagram
CCB-BOSSANOVA
© EKF

Sheet 2/3
IDE Storage Options

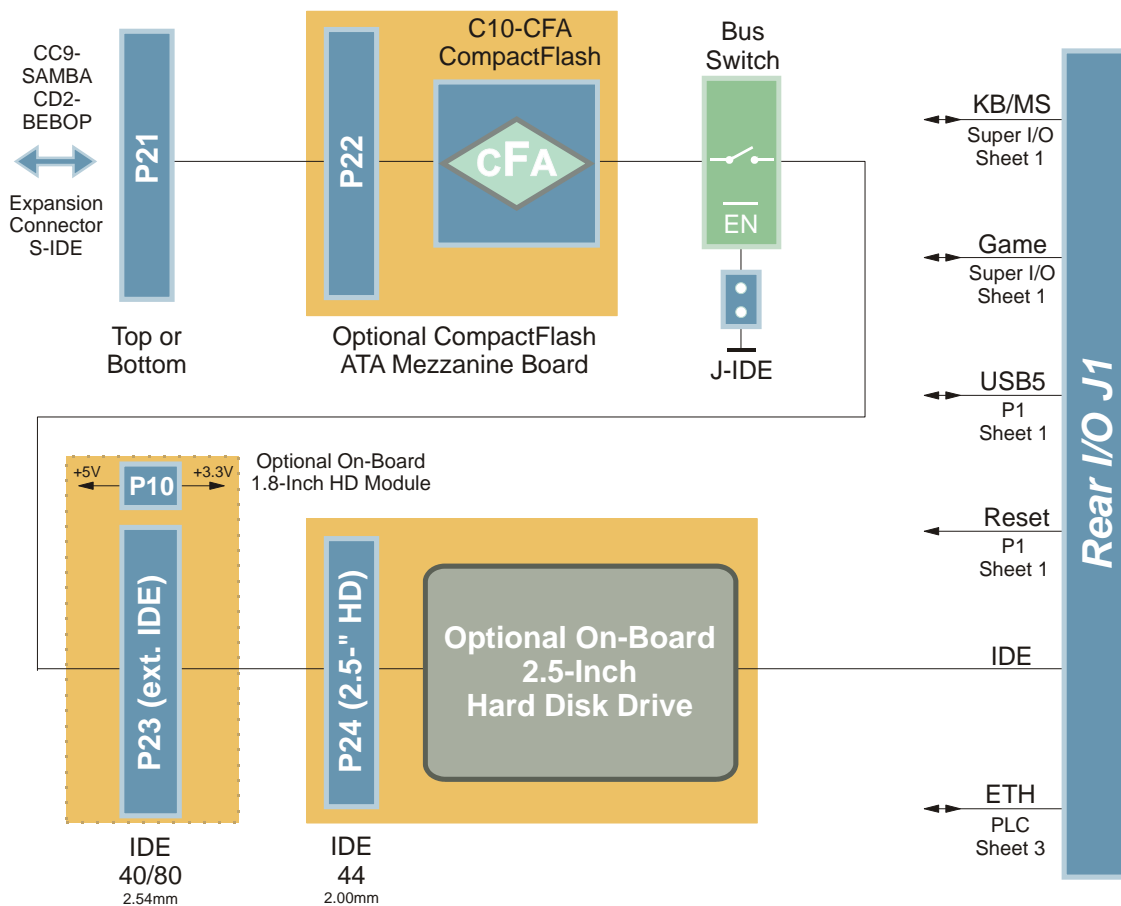

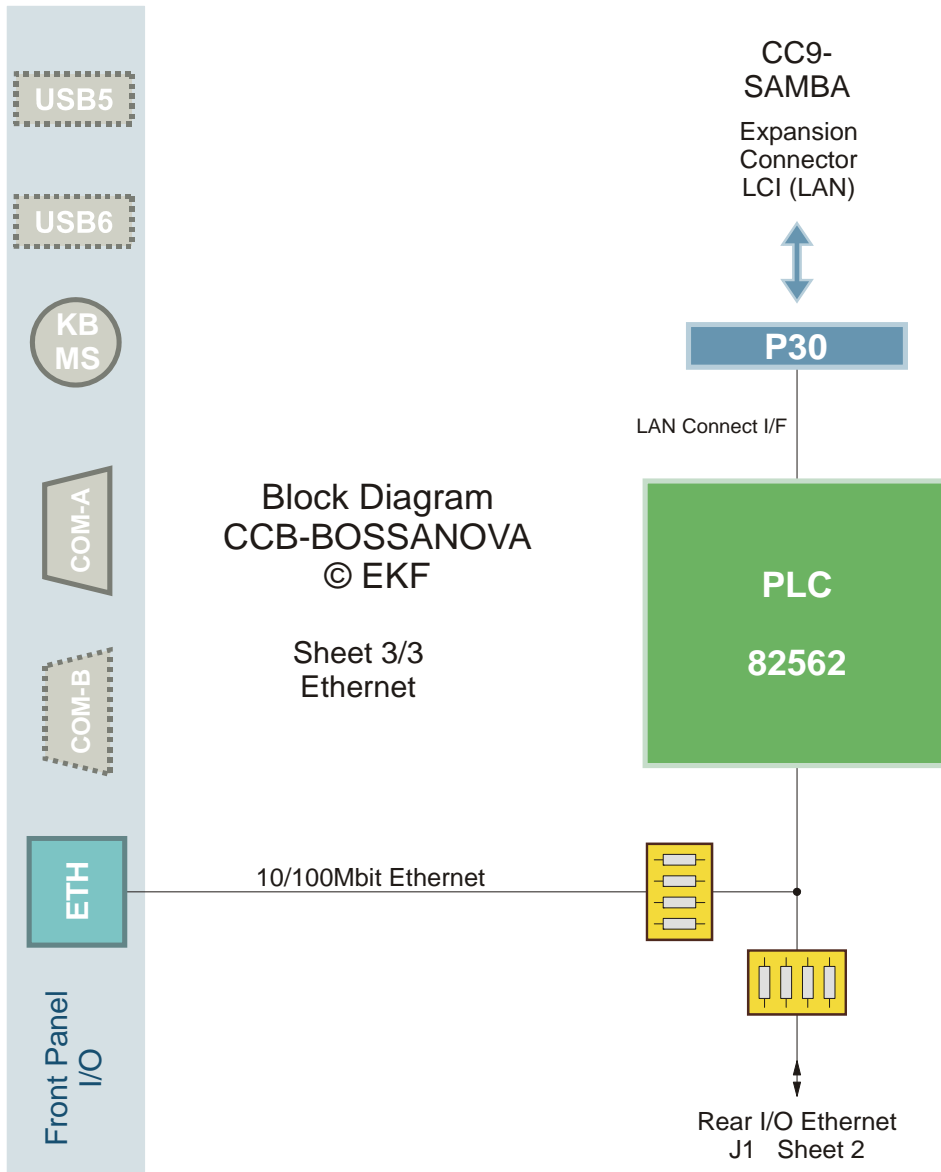

Block Diagram CCZ-RIO

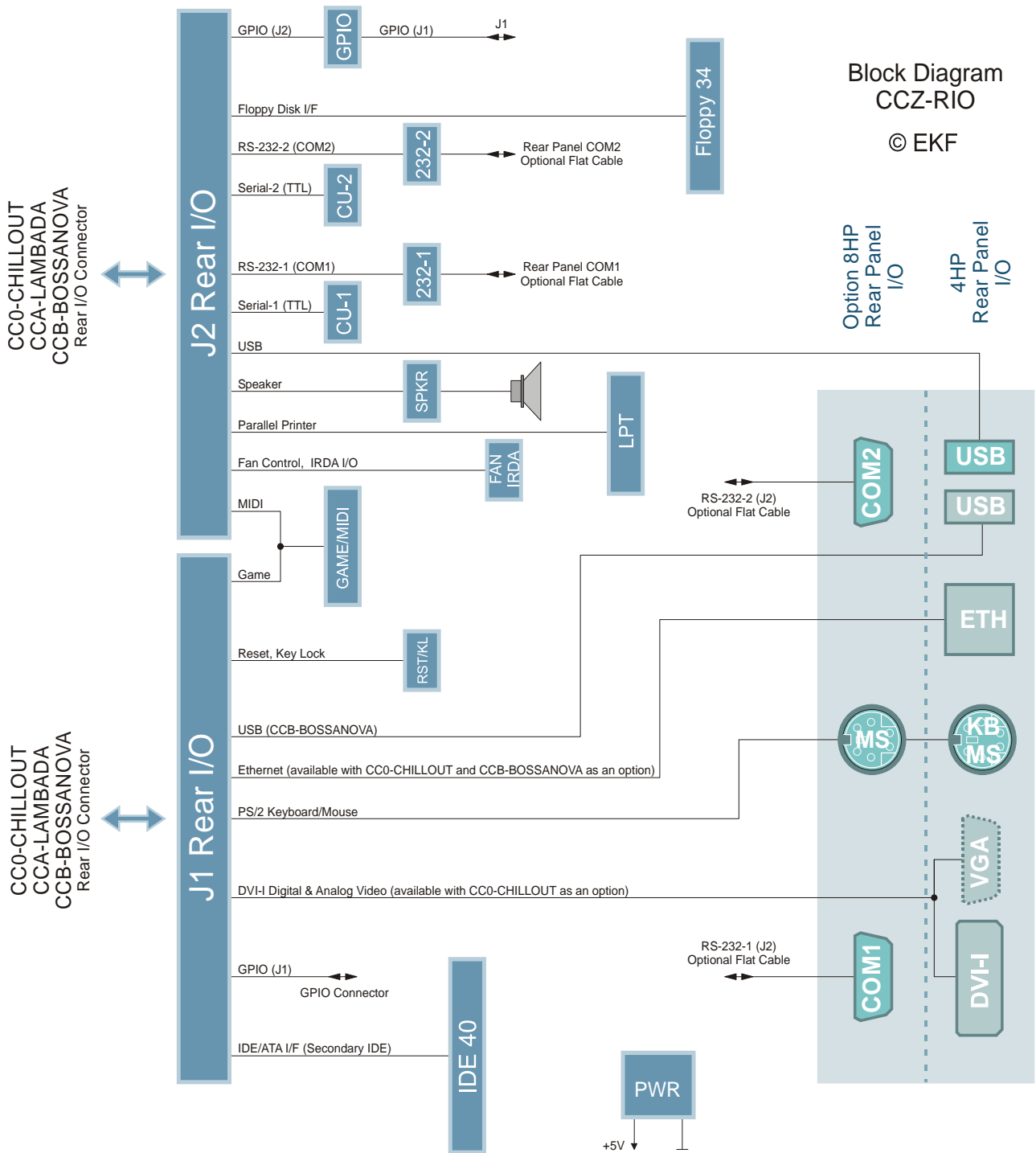

Block Diagram CCZ-RIO

© EKF

Top View Component Assembly CCB-BOSSANOVA

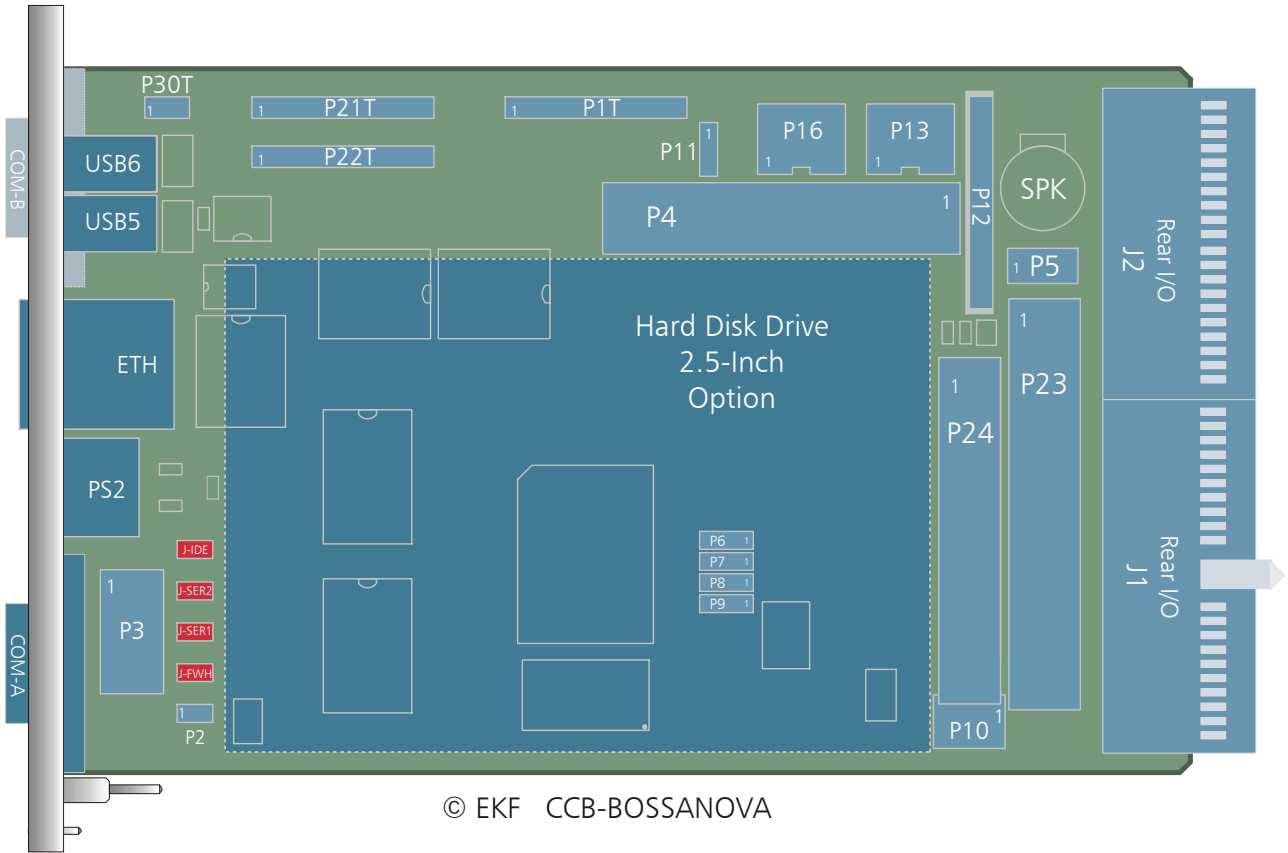

On-Board Connectors

P1	Main (first) expansion interface connector (socket, available from top or bottom of the PCB) <ul style="list-style-type: none"> • LPC Low Pin Count interface • AC'97 Audio Codec • USB5, USB6 • GPIO, Speaker, Reset
P2	Reset (hardware reset to the host CPU, pin header)
P3	GPIO General Purpose Inputs/Outputs pin header
P4	Floppy disk header 34-pin
P5	Floppy disk power
P6..P9	Fan heatsink pin headers
P10	Drive power connector, for future use together with P23 IDE connector
P11	MIDI interface pin header
P12	Floppy disk header 26-pos. ZIF socket (slim-line drive)
P13	Serial port 1 (TTL level), pin header suitable for EKF CU-series PHY module
P16	Serial port 2 (TTL level), pin header suitable for EKF CU-series PHY module
P21	Second expansion interface connector (socket, available from top or bottom of the PCB) <ul style="list-style-type: none"> • Secondary IDE/ATA Interface
P22	Socket for C10-CFA CompactFlash adapter mezzanine module
P23	IDE 40-pin header for an external DVD drive or hard disk drive (3.5-inch), optionally to be used together with P10 drive power connector (future mezzanine modules)
P24	IDE 44-pin header for an on-board hard disk drive (2.5-inch)
P30	Third expansion interface connector (socket, available from top or bottom of the PCB) <ul style="list-style-type: none"> • LAN Connect Interface (LCI), suitable for Intel 82562
J1	Rear I/O metric connector 5 x 25 brown key
J2	Rear I/O metric connector 5 x 22

Please note: Not all of these connectors may be present or functional on your actual CCB-BOSSANOVA board. Assembly of these connectors is highly custom specific. Discuss your needs with EKF before ordering.

Front Panel Connectors

COM-A ^{1 2}	RS-232E serial communications port (CCB on-board SIO2 COM-A), D-Sub 9-position male connector
COM-B ^{1 2}	RS-232E serial port (CCB on-board SIO2 COM-B), D-Sub 9-position male connector, provided on CCB-2-LAMBADA only
ETH	Ethernet 10/100Mbps (Fast Ethernet), RJ45 jack
KB/MS	PS/2 keyboard connector (PS/2 mouse with additional splitter cable)
USB5 ¹	USB connector (CC9-SAMBA USB5 port), provided on CCB-1-LAMBADA only
USB6 ¹	USB connector (CC9-SAMBA USB6 port), provided on CCB-1-LAMBADA only

¹ Not all of these connectors may be present or functional on your actual CCB-BOSSANOVA board. Assembly of these connectors is highly custom specific. Discuss your needs with EKF before ordering.

² Due to a primary SIO which may be present on the CPU board itself, the BIOS may assign different COM port numbers to these interface lines.

Jumpers

J-FWH ¹	Determines if the optional on-board firmware hub is acting as boot BIOS (jumper set) or as secondary BIOS (jumper removed).
J-IDE ¹	Enables IDE bus switches when set. Please note: In order to make use of either connector P23 (external IDE device), P24 (2.5-inch on-board hard disk) or rear I/O IDE across J1, the jumper J-IDE must be set. However, if neither P23..P24 nor J1 IDE is in use, J-IDE must be removed in order to avoid reflections on the IDE bus caused by tapped signal traces.
J-SER1 ¹	Enables the optional RS-232 transceiver (on-board SIO COM-A) when set. If removed, the transceiver is in a high-impedance shutdown mode. J-SER1 must be set in order to make use of the front panel connector COM.
J-SER2 ¹	Enables the optional RS-232 transceiver (on-board SIO COM-B) when set. If removed, the transceiver is in a high-impedance shutdown mode.

¹ Not all of these jumpers may be present or functional on your actual CCB-BOSSANOVA board. Assembly of these jumpers is highly custom specific. Discuss your needs with EKF before ordering.

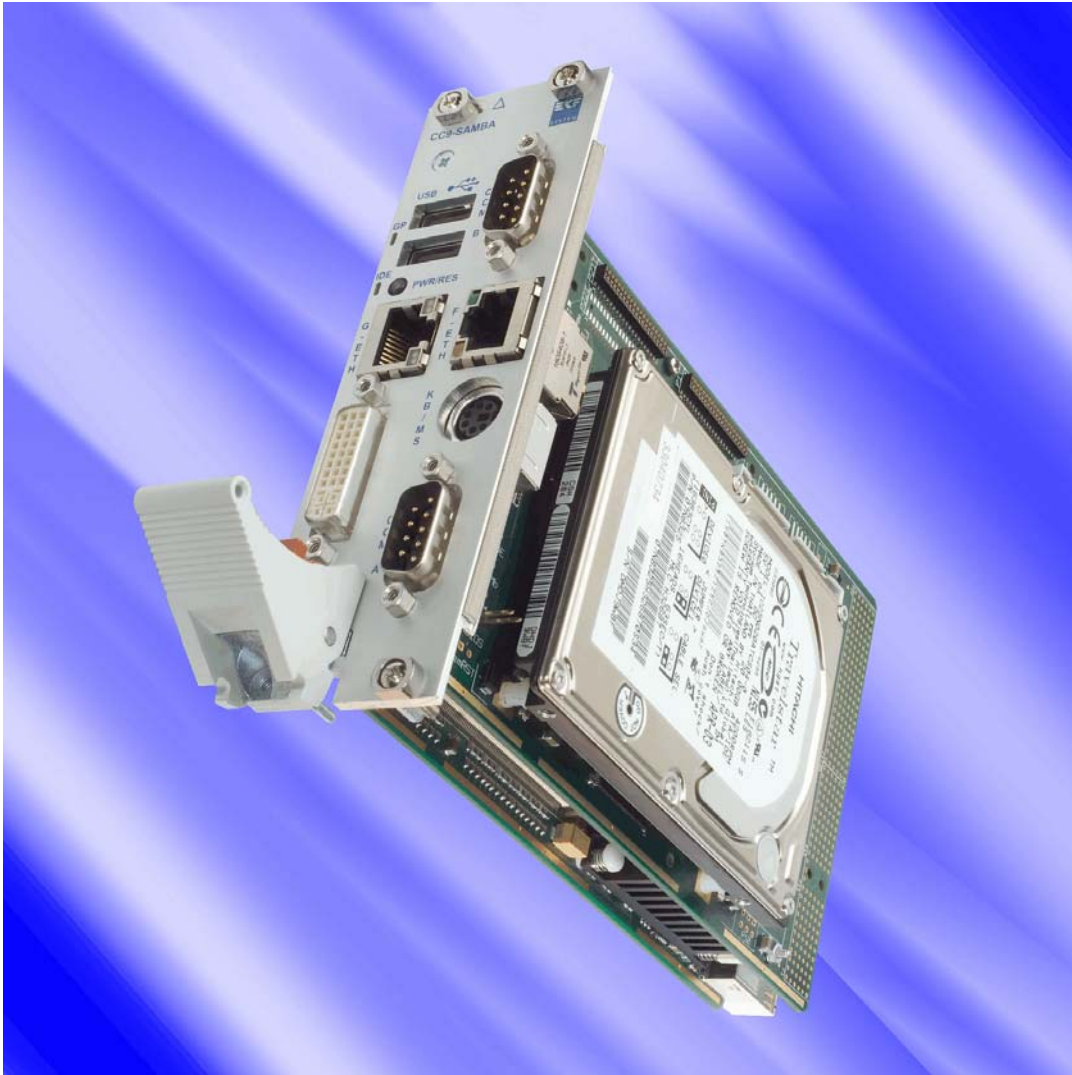

CCB-2-BOSSANOVA with Hard Disk Option



Front Panel CF Card Slot on Top of the CCB-2-BOSSANOVA

Installing and Replacing Components

Before You Begin

Warnings

The procedures in this chapter assume familiarity with the general terminology associated with industrial electronics and with safety practices and regulatory compliance required for using and modifying electronic equipment. Disconnect the system from its power source and from any telecommunication links, networks or modems before performing any of the procedures described in this chapter. Failure to disconnect power, or telecommunication links before you open the system or perform any procedures can result in personal injury or equipment damage. Some parts of the system can continue to operate even though the power switch is in its off state.



Caution

Electrostatic discharge (ESD) can damage components. Perform the procedures described in this chapter only at an ESD workstation. If such a station is not available, you can provide some ESD protection by wearing an antistatic wrist strap and attaching it to a metal part of the system chassis or board front panel. Store the board only in its original ESD protected packaging. Retain the original packaging (antistatic bag and antistatic box) in case of returning the board to EKF for rapair.



Installing the Board

Warning

This procedure should be done only by qualified technical personnel. Disconnect the system from its power source before doing the procedures described here. Failure to disconnect power, or telecommunication links before you open the system or perform any procedures can result in personal injury or equipment damage.

Typically you will perform the following steps:

- Switch off the system, remove the AC power cord
- Attach your antistatic wrist strap to a metallic part of the system
- Remove the board packaging, be sure to touch the board only at the front panel
- Identify the related CompactPCI slot (peripheral slot for I/O boards, system slot for CPU boards, with the system slot typically most right or most left to the backplane)
- Insert card carefully (be sure not to damage components mounted on the bottom side of the board by scratching neighbored front panels)
- A card with onboard connectors requires attachment of associated cabling now
- Lock the ejector lever, fix screws at the front panel (top/bottom)
- Retain original packaging in case of return



Removing the Board

Warning

This procedure should be done only by qualified technical personnel. Disconnect the system from its power source before doing the procedures described here. Failure to disconnect power, or telecommunication links before you open the system or perform any procedures can result in personal injury or equipment damage.

Typically you will perform the following steps:

- Switch off the system, remove the AC power cord
- Attach your antistatic wrist strap to a metallic part of the system
- Identify the board, be sure to touch the board only at the front panel
- unfasten both front panel screws (top/bottom), unlock the ejector lever
- Remove any onboard cabling assembly
- Activate the ejector lever
- Remove the card carefully (be sure not to damage components mounted on the bottom side of the board by scratching neighbored front panels)
- Store board in the original packaging, do not touch any components, hold the board at the front panel only



Warning

Do not expose the card to fire. Battery cells and other components could explode and cause personal injury.





EMC Recommendations

In order to comply with the CE regulations for EMC, it is mandatory to observe the following rules:

- The chassis or rack including other boards in use must comply entirely with CE
- Close all board slots not in use with a blind front panel
- Front panels must be fastened by built-in screws
- Cover any unused front panel mounted connector with a shielding cap
- External communications cable assemblies must be shielded (shield connected only at one end of the cable)
- Use ferrite beads for cabling wherever appropriate
- Some connectors may require additional isolating parts (e.g. 10Base-2 BNC T-connector)

Reccomended Accessories

Blind CPCI Front Panels	EKF Elektronik	Widths currently available (1HP=5.08mm): with handle 4HP/8HP without handle 2HP/4HP/8HP/10HP/12HP
Ferrit Bead Filters	ARP Datacom, 63115 Dietzenbach	Ordering No. 102 820 (cable diameter 6.5mm) 102 821 (cable diameter 10.0mm) 102 822 (cable diameter 13.0mm)
Isolating Elements	ARP Datacom, 63115 Dietzenbach	Ordering No. 182 068 (Cheapernet T-connector)
Metal Shielding Caps	Conec-Polytronic, 59557 Lippstadt	Ordering No. CDFA 09 165 X 13129 X (DB9) CDSFA 15 165 X 12979 X (DB15) CDSFA 25 165 X 12989 X (DB25)

Technical Reference - Connectors

Caution

Some of the connectors provide operating voltage (e.g. 5V and 3.3V) to devices inside the system chassis, such as fans and internal peripherals. Not all of these connectors are overcurrent protected. Do not use these connectors for powering devices external to the computer chassis. A fault in the load presented by the external devices could cause damage to the board, the interconnecting cable and the external devices themselves.

Please Note

The CCB-BOSSANOVA transition module may be equipped with several on-board connectors for system internal usage. Not all of these connectors may be present on a particular board. Be sure to specify your individual needs when ordering the CCB board. Characteristic features and the pin assignments of each connector are described on the following pages (connector designation in alphabetical order within the groups 'front panel connectors', 'on-board connectors', and 'rear I/O connectors').

Front Panel Connectors

By default, the CCB-BOSSANOVA shares an 8HP (~40.6mm) front panel with the CPU carrier board. Further more, custom specific front panel options are available on request.

As of current, suitable CPU cards for use together with the CCB-BOSSANOVA are the CC9-SAMBA and CD2-BEBOB. The basic version of the CCB-BOSSANOVA may be mounted either left or right (top or bottom) with respect to the CC9-SAMBA or another suitable CPU carrier board, which results in two different front panel versions for the CPU and the companion board (illustrated below is only the top mounting situation). When the J1/J2 rear I/O connectors of the CCB-BOSSANOVA are stuffed, be sure to position the board outside of the CPCI main backplane (this slot can be either right or left from the CPU board, dependent of where the system controller slot is situated on the backplane - right most or left most).

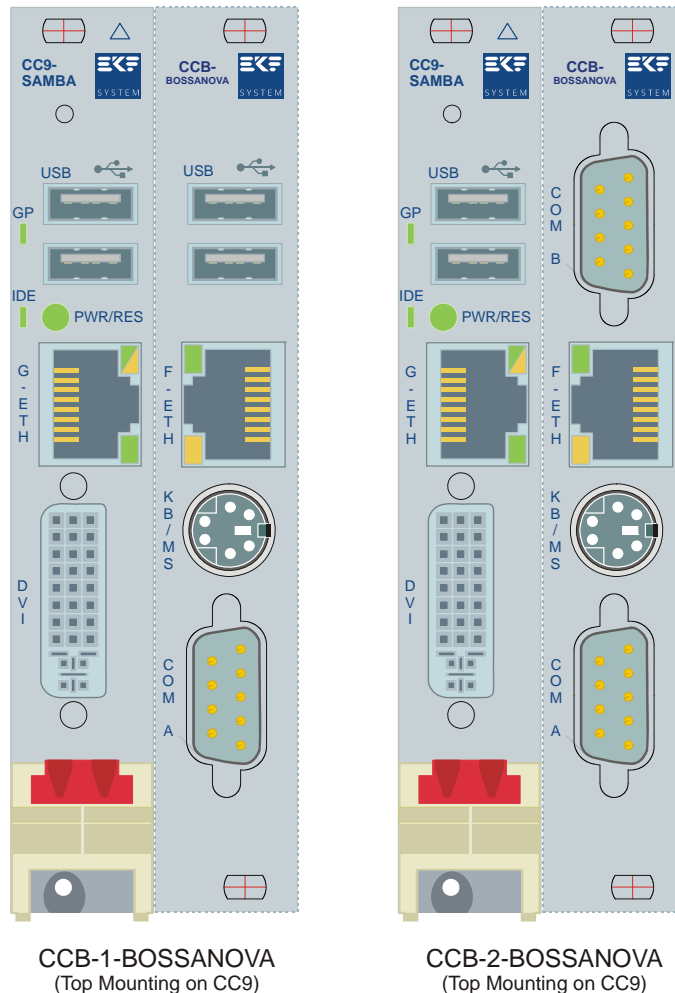

COM-A/COM-B Serial Port Connectors

The on-board secondary Super-I/O (SIO) on the CCB-BOSSANOVA provides two asynchronous serial interfaces. Due to another (primary) SIO typically available on the CC9-SAMBA host board, the serial interfaces are not necessarily dedicated to the COM-1/COM-2 ports of a typical PC. Verify or modify the accompanying CC9 BIOS settings for mapping of physical asynchronous serial I/O ports to the logical COM port order. Being ignorant of the actual port mapping, the serial port front panel connectors are marked neutrally as COM-A and COM-B. While COM-A is present on both front panels CCB-1 and CCB-2, COM-B is available only with CCB-2-BOSSANOVA. On the CCB-1 front panel this space is assigned to USB connectors instead.

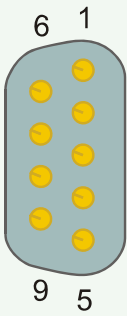
COM-A/COM-B RS-232 Male D-Sub 9				
			1	DCD
	DSR	6		
			2	RXD
	RTS	7		
			3	TXD
	CTS	8		
			4	DTR
	RI	9		
			5	GND

The on-board ESD protected RS-232E transceivers on the CCB-BOSSANOVA allow a bitrate of up to 230kbps. In order to make use of the front panel connectors COM-A and/or COM-B, the associated jumper(s) J-SER1 and/or J-SER2 must be set, which in turn enable(s) the associated transceiver(s). Please note that neither J-SER1 nor J-SER2 may be necessarily stuffed. A resistor combination may be present instead to simulate the jumpers.

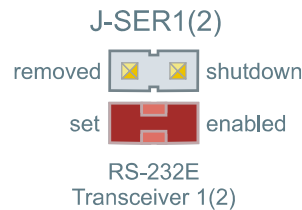

The COM ports are alternatively also available across J2 as rear I/O communications interface. Be sure not to attach peripherals on both line endings simultaneously, the front panel connector and the rear I/O connector, which would result in interfering data.

KB/MS PS/2 Keyboard & Mouse Connector

The PS/2 Mini-Din connector incorporates both inputs, keyboard and mouse. This method allows solely attachment of a PS/2 keyboard, or usage of a keyboard and a mouse by means of an additional splitter cable (available as accessory to notebook computers or from EKF).

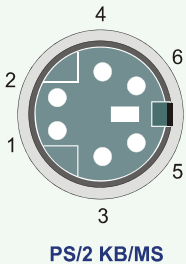
PS/2 KB/MS Mini-Din 6-Position		
 <p>PS/2 KB/MS</p>	1	DAT KB
	2	DAT MS 2)
	3	GND
	4	5V_KM 1)
	5	CLK KB
	6	CLK MS 2)

1) Fused by PolySwitch

2) Splitter cable required for attachment of both keyboard and mouse (EKF 280.7.400)

Please note: When using the splitter cable for simultaneous attachment of keyboard and mouse, the mouse connector must be plugged onto the receptacle marked as keyboard, and vice versa (this is true for the splitter cable part no. 280.7.400 by EKF).

Ethernet Connector

In addition to the primary Gigabit Ethernet port (10/100/1000Mbps) on the CC9-SAMBA, the CCB-BOSSANOVA is optionally provided with a secondary Fast Ethernet port (10/100Mbps). The RJ45 jack incorporates two LEDs which signal status information when the CCB-BOSSANOVA is attached to an Ethernet network.

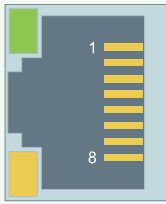
Fast Ethernet RJ45 Jack		
 <p>Upper green LED: on=link established blinking=activity (data)</p> <p>Lower yellow LED: on=100Mbit/s off=10Mbit/s</p>	1	TX+
	2	TX-
	3	RX+
	4	
	5	
	6	RX-
	7	
	8	

The MAC address of the secondary Ethernet port is not stored on the CCB-BOSSANOVA itself, but requires an EEPROM to be present on the CC9-SAMBA instead, which is attached to the ICH4 controller chip with integrated LAN functionality. Through the LAN Connect Interface (LCI) bus the ICH4 communicates with the 82562 Platform LAN Connect (PLC) controller on the CCB-BOSSANOVA, which can be seen as a PHY with respect to the Ethernet twisted pair copper line.

The secondary Ethernet port is available as an option. Other potential host CPU boards than the CC9-SAMBA, such as the CD2-BEBOP, may not provide the LCI expansion connector, which would result in a non-operational Ethernet port on the CCB-BOSSANOVA.

USB Connectors USB5/USB6

Front panel USB is available only for the CCB-1-BOSSANOVA. The host CPU board CC9-SAMBA is equipped with an ICH4 (Input/Output Controller Hub), which incorporates six USB 1.1/2.0 ports. The ports 5 and 6 are routed across the connector P1 to the CCB-BOSSANOVA companion board.

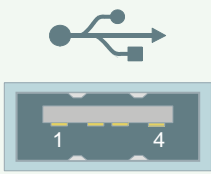
USB5/USB6 (Front Panel)		
 <p>1) Electronic Fuse</p>	1	+5V_USB5/6 0.5A 1)
	2	DATA5/6-
	3	DATA5/6+
	4	GND

On the CCB-2-BOSSANOVA, which does not provide front panel USB, USB port 6 is available for rear I/O on J2, and USB port 5 is wired through J1.

On-Board Connectors

The CCB-BOSSANOVA can be equipped with several on-board connectors. Some of these connectors are available as an option only or exclusive to each other, and therefore may not be present on your actual board.

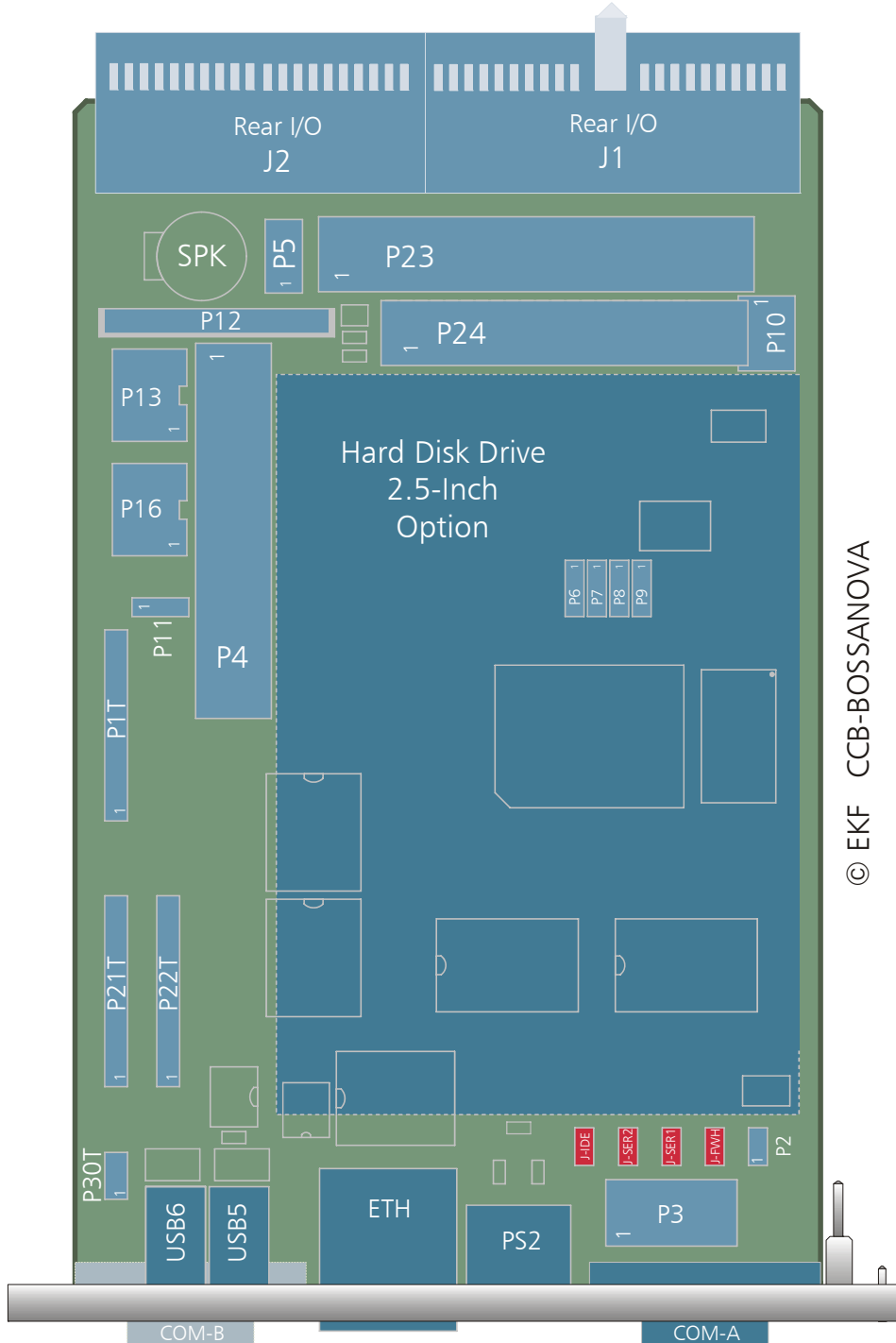

P1 Expansion Connector LPC/USB

The expansion connector P1 is mounted either on top, on bottom, or on both sides of the CCB-BOSSANOVA PCB. This allows to attach the CCB either on top (EKF standard) or on bottom of the CPU carrier board.

P1 (P1T/P1B) Expansion Board Interface (LPC/AC'97/USB/GPIO) 1.27mm Socket 2 x 20

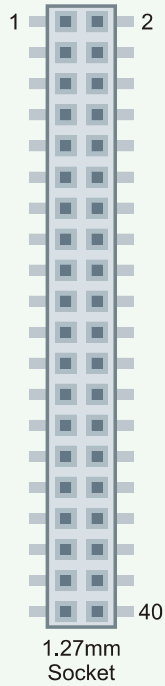

GND	1	2	+3.3V
pciclk	3	4	pcirst#
lad0	5	6	lad1
lad2	7	8	lad3
lframe	9	10	ldrq#
GND	11	12	+3.3V
serirq	13	14	lpme#
lsmi#	15	16	sio_clk14
fwhid0	17	18	fwhinit#
kbrst#	19	20	a20gate
GND	21	22	+5V
usb6_d-	23	24	usb5_d-
usb6_d+	25	26	usb5_d+
usb56_oc#	27	28	reset#
gp16	29	30	gp17
GND	31	32	+5V
ac_sdout	33	34	ac_sdin0
ac_rst	35	36	ac_sync
ac_bitclk	37	38	ac_sdin1
speaker	39	40	NC

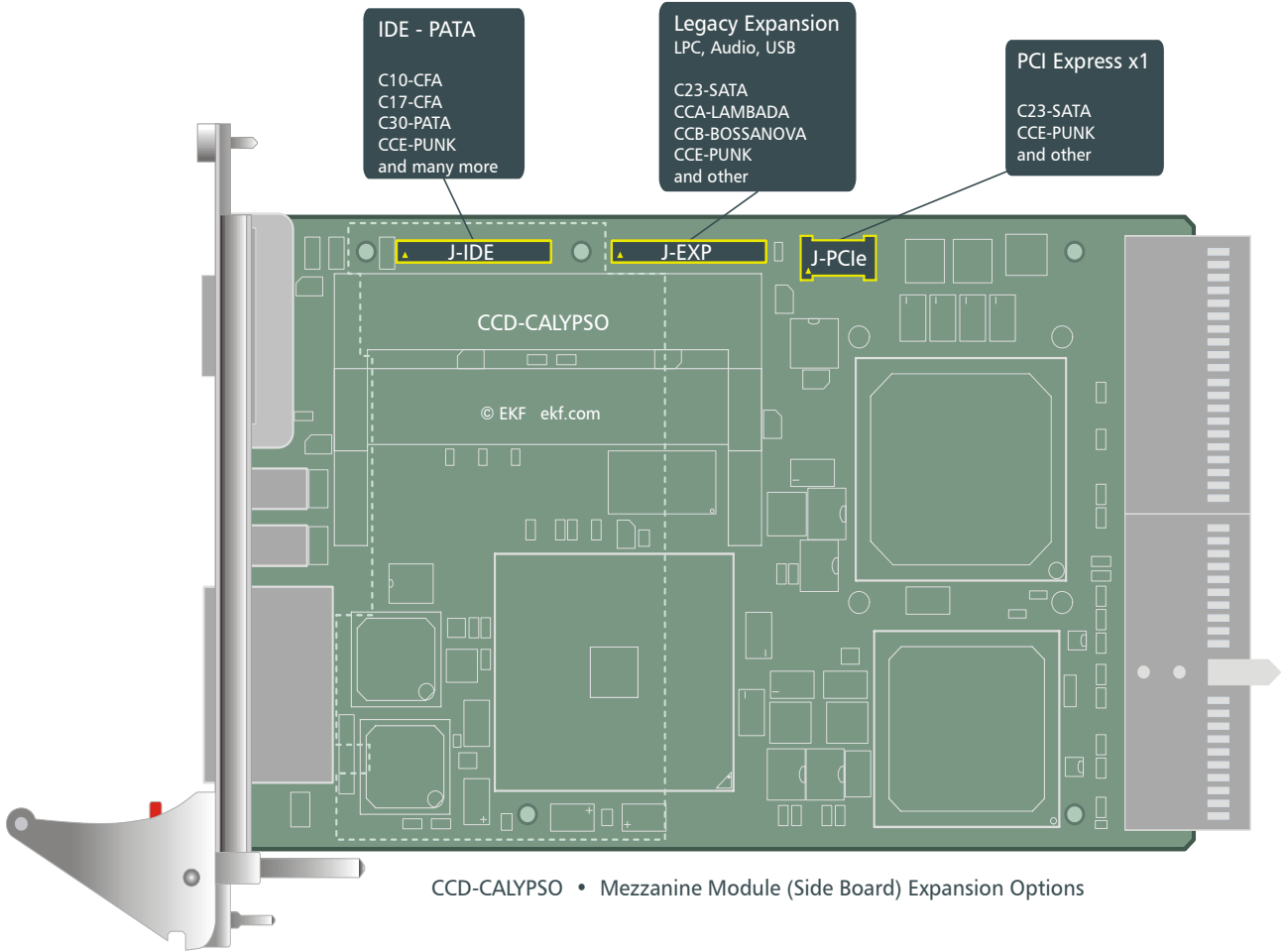

Mezzanine Connectors on a CPU Carrier Board

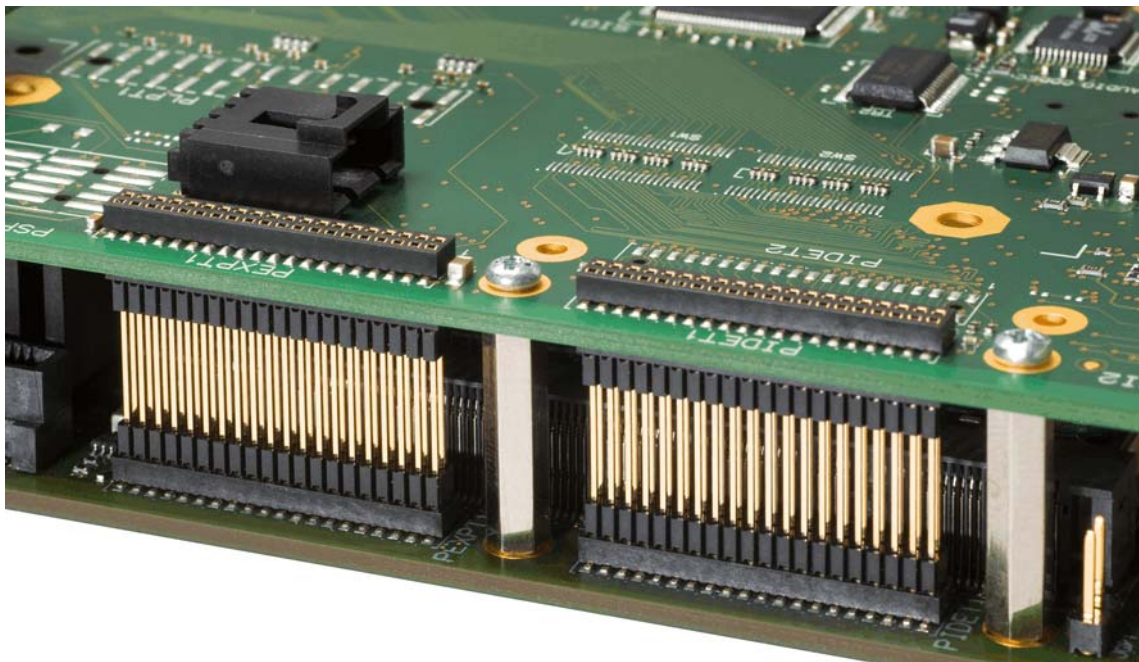

P-EXP (left) & P-IDE (right)

P2 Reset

Provided as an option, the pin header P2 can be used for resetting the CPU host board (processor reset) if wired to additional circuitry (e.g. watchdog or manual pushbutton). Tie reset# to GND with an open collector output.

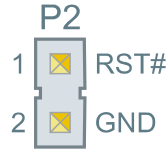

P3 General Purpose Inputs/Outputs

The optional connector P3 can be used for general purpose digital I/O. Please note, that these signals are also available for rear I/O on J2 - do not attach peripherals to both endings of a particular GPIO line. The GPI signals **GPI1** and **GPI2** are not 5V tolerant.

P3 GPIO 2.54mm Pin Header 2 x 5				
	GPI1 (on-Board FWH2) Input, 4.7k P/D, 3.3V only - not 5V tol.	1	2	GPI2 (on-Board FWH2) Input, 4.7k P/D, 3.3V only - not 5V tol.
	GPIO16 (CC9-SAMBA SIO1) I/O, P/U 50K, 24mA, Input 5V tol.	3	4	GPIO17 (CC9-SAMBA SIO1) I/O, P/U 50K, 24mA, Input 5V tol.
	GPIO21 (on-Board SIO2) I/O12, OD12, Input 5V tol.	5	6	GPIO22 (on-Board SIO2) I/O12, OD12, Input 5V tol.
	GPIO43 (on-Board SIO2) I/O8, OD8, Input 5V tol.	7	8	GPIO60 (on-Board SIO2) I/O12, OD12, Input 5V tol.
	GPIO61 (on-Board SIO2) I/O12, OD12, Input 5V tol.	9	10	GND

- IO12 Input/Output, 12mA sink, 6mA source
- OD12 Open Drain Output, 12mA sink
- IO8 Input/Output, 8mA sink, 4mA source
- OD8 Open Drain Output, 8mA sink

In addition, even more GPIO signals are available on P6..P9, P10, P11, P16..P17, J1, J2.

P4 Floppy Disk Connector

As an option, the CCB-BOSSANOVA is provided with a 34-pin header, suitable for attachment of a single floppy disk drive with mating connector across a suitable micro ribbon flat cable harness.

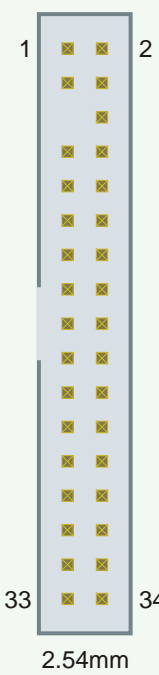
P4 Floppy Disk Interface 2.54mm Pin Header				
	GND	1	2	drvden0#
	GND	3	4	NC
	KEY	5	6	drvden1#
	GND	7	8	index#
	GND	9	10	mtr0#
	GND	11	12	NC
	GND	13	14	ds0#
	GND	15	16	NC
	GND	17	18	dir#
	GND	19	20	step#
	GND	21	22	wdata#
	GND	23	24	wgate#
	GND	25	26	trk0#
	GND	27	28	wrtprt#
	NC	29	30	rdata#
	GND	31	32	hdssel#
	NC	33	34	dskchg#

As an alternative, P12 is optionally available for attachment of a slim-line floppy drive. Since all floppy lines are as well available for rear I/O across J2, be sure to have only one of either P4, or P12, or the rear I/O floppy disk connector in use.

P5 Power Connector

The initial purpose of the optional connector P5 was to deliver +5V power to an attached floppy disk drive (if wired to P4). A suitable cable assembly matching the AMP 171826-4 would be required. Alternatively, P5 can be used to pass +5V redundantly (in addition to the expansion interface connector P1) to the CCB-BOSSANOVA, which can improve the power distribution when an on-board hard disk drive is in use (especially if a pair of drives is connected to P24). The current across P5 is limited by resettable fuses.

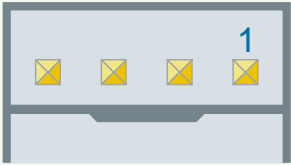
P5 Floppy Disk Power (External Power)		
 <p>AMP 171826-4</p>	1	+5V_FD 1.5A
	2	GND
	3	GND
	4	+12V_FD 0.5A

If a floppy disk drive which requires +12V is supplied with power by P5, one of the header connectors P6..P9 must be used to derive +12V from an external power supply. There is no +12V feeding node available on the CCB-BOSSANOVA other than P6..P9 (+12V is also wired to J1, but would normally not be accessible for strapping, i.e. a custom specific rear I/O backplane would be required for sourcing +12V across J1).

P6..P9 Cooling Fan Headers

The on-board SIO2 is provided with control ports for cooling fans with either a tachometer output (P6/P7) or PWM input (P8/P9). The benefit of a tachometer is to realize a fan operation failure, which would allow to punctual shutdown a system before a damage can occur. A fan with PWM input would allow to control the number of revolutions dependent from the CPU temperature, which can increase the lifetime of a fan considerably. The optional pin-headers P6..P9 could be used for attachment of suitable cooling fans.

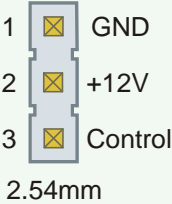
P6 - P9 (2.54mm Pin Row)		
	1	GND
	2	+12V 2.5A (in total)
	3	Tachometer (P6/P7) Pulse Width Modulation (P8/P9)

If a +12V fan is supplied with power by either connector P6..P9, one of the remaining connectors P6..P9 must be used to derive +12V from an external power supply. There is no +12V/2.5A feeding node available on the CCB-BOSSANOVA other than P6..P9 (+12V is also wired to J1, but would normally not be accessible for strapping, i.e. a custom specific rear I/O backplane would be required for sourcing +12V across J1).

If P6..P9 are not required for fan control, the pins 3 of each header can be used as additional GPIOs:

P6	GPIO30
P7	GPIO31
P8	GPIO32
P9	GPIO33

Since all fan control lines are as well available for rear I/O across J2, be sure to have connected any signal only once, in order to avoid interference.

P10 Power Connector

The optional on-board power connector P10 can be used together with the IDE connector P23 for a future mezzanine module, e.g. with an 1.8-inch hard disk.

P10 Power 2.54mm Pin Header Dual Row 2 x 3				
	+3.3V	1	2	+3.3V
	GND	3	4	GND
	+5V	5	6	+5V

P11 MIDI Header

As an option, a single row pin-header is stuffed, which in addition to P10 (or as an alternative) provides MIDI I/O.

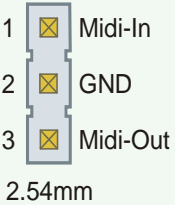
P11 MIDI 2.54mm Pin Header Single Row	
	1 MIDI-IN / GPIO25
	2 GND
	3 MIDI-OUT / GPIO26

P12 Micro Floppy Disc Connector

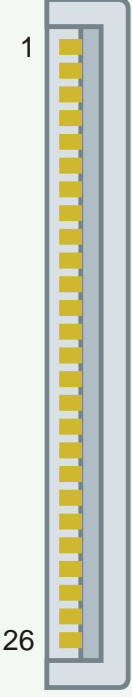
P12 Slim Line Floppy Disk 1mm ZIF Receptacle		
 <p>1mm pitch FFC/FPC receptacle vertical ZIF 26-position</p>	1	+5V_FDS 1)
	2	index#
	3	+5V_FDS 1)
	4	ds0#
	5	+5V_FDS 1)
	6	dskchg#
	7	NC
	8	NC
	9	drvden0#
	10	mtr0#
	11	NC
	12	dir#
	13	modsel
	14	step#
	15	GND
	16	wdata#
	17	GND
	18	wgate#
	19	GND
	20	trk0#
	21	NC
	22	wrtprt#
	23	GND
	24	rdata#
	25	GND
	26	hdsel#

1) Fused by PolySwitch 1.5A

In addition to P4, the CCB-BOSSANOVA may be also provided with a 26-position FFC/FPC ZIF socket, suitable for attachment of a single floppy disk drive with mating connector (typically low profile drives, e.g. TEAC FD05HF5630, Y-E Data YD-702J-6637, Citizen X1DE-00R, Mitsumi D353F3, Samsung SFD-321S, NEC FD1238H).

You may chose either one for floppy disk drive attachment, the P4 connector or P12 or rear I/O across J2, but not two of them simultaneously.

P13/P16 Serial Port 1/2 CU-Module Header

The on-board SIO2 is provided with two asynchronous serial interfaces. For attachment of EKF CU-series PHY modules via a micro ribbon flat cable assembly, the CCB-BOSSANOVA is optionally equipped with suitable pin-headers. A PHY module is a transceiver from TTL level signals to a specific symmetric or asymmetric interface standard, e.g. EIA-485 or RS-232E, with or w/o galvanic isolation. Usage of a PHY module requires that the associated on-board RS-232 transceiver is either disabled (J-SER1/2 removed) or not stuffed.

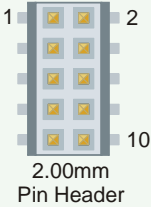
P13 & P16 Serial I/O CU-Module Standard 2.00mm Pin Header 2 x 5				
 <p>2.00mm Pin Header</p> <p>1) fused by PolySwitch</p>	+5V_SER1(2) 0.5A 1)	1	2	DSR1(2)# / GPIO54 / IRQ9
	RI1(2)# / GPIO50 / IRQ3	3	4	RXD1(2) / GPIO52 / IRQ5
	TXD1(2) / GPIO53 / IRQ7	5	6	DTR1(2)# / GPIO57 / IRQ15
	RTS1(2)# / GPIO55 / IRQ10	7	8	CTS1(2)# / GPIO56 / IRQ11
	DCD1(2)# / GPIO51 / IRQ4	9	10	GND

The triple function (GPIO or IRQ in addition to the UART) is available solely for the serial port 2 (P16). Since all lines are as well available for rear I/O across J2, be sure to have connected any signal only once, in order to avoid interference.

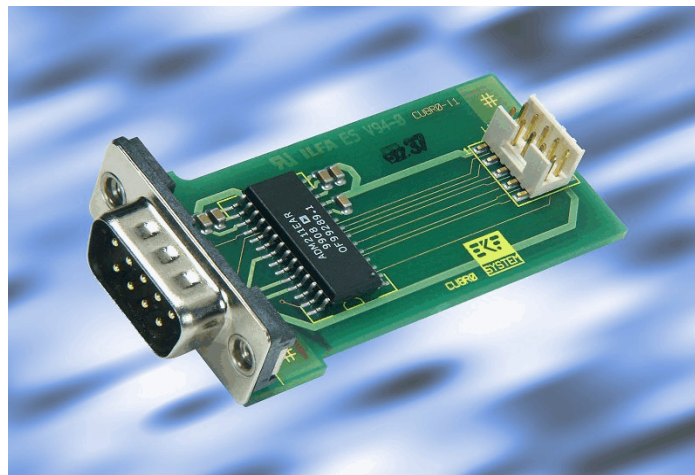

CU-Series PHY Module

P21/P22 IDE Expansion Connector & CompactFlash Mezzanine Connector

The expansion connector P21 is mounted either on top, on bottom, or on both sides of the CCB-BOSSANOVA PCB. This allows to attach the CCB either on top (EKF standard) or on bottom of the CPU carrier board. In addition to the expansion interface connector P1, which incorporates mainly the LPC interface, P21 is dedicated to the Secondary-IDE channel of the ICH4 (Input/Output Controller Hub) on the host CPU board.

The optional connector P22 is identical to P21 and may be used for a mezzanine module with a CompactFlash socket (EKF C10-CFA, part of the CC9-SAMBA and CCD-CALYPSO) or an 1.8-inch hard disk mezzanine module (C30-PATA).

P21 (P21T/P21B) & P22 CompactFlash/IDE Expansion Interface 1.27mm Socket 2 x 20

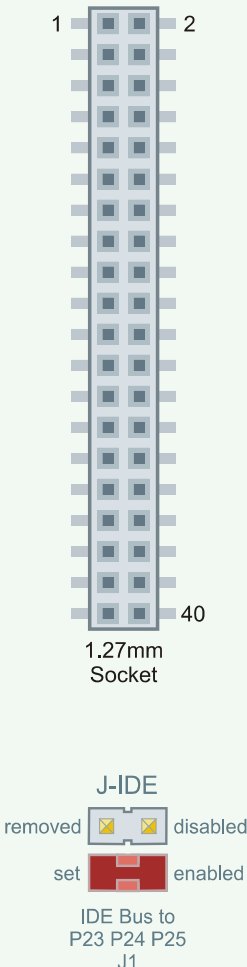

ide0_reset#	1	2	GND
ide0_dd07	3	4	ide0_dd08
ide0_dd06	5	6	ide0_dd09
ide0_dd05	7	8	ide0_dd10
ide0_dd04	9	10	ide0_dd11
ide0_dd03	11	12	ide0_dd12
ide0_dd02	13	14	ide0_dd13
ide0_dd01	15	16	ide0_dd14
ide0_dd00	17	18	ide0_dd15
GND	19	20	+3.3V
ide0_dmarq	21	22	+3.3V
ide0_diow#	23	24	GND
ide0_dior#	25	26	GND
ide0_iordy	27	28	+5V
ide0_dmack#	29	30	+5V
ide0_intrq	31	32	GND
ide0_da1	33	34	ide0_cblid#
ide0_da0	35	36	ide0_da2
ide0_cs1#	37	38	ide0_cs3#
ide0_act#	39	40	GND

IDE Bus to P23 P24 P25 J1

If the CompactFlash adapter module is the only IDE device on the CCB-BOSSANOVA and no rear I/O IDE is required, the IDE signal lines to all other IDE connectors P23, P24 and J1 should be interrupted (remove jumper J-IDE, which in turn disables an electronic bus switch). This helps to avoid reflections on the IDE bus, which could otherwise degrade the signal quality.



C10-CFA (Top Mount)



C17-CFA (Bottom Mount)

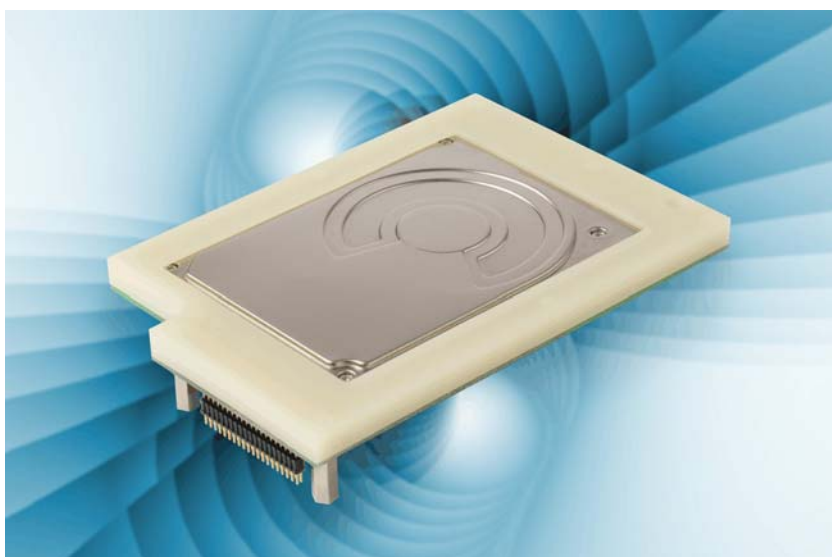

C30-PATA 1.8-Inch SSD (Top Mount)



C30-PATA Hooked on P-IDE

P23 External IDE Header

P23 is provided optionally for attachment of classic IDE devices (e.g. 3.5-inch hard disk drive, DVD-ROM). In addition, P23 may be used in combination with the power connector P10 to attach an optional 1.8-inch hard disk mezzanine module.

Usage of the IDE connector P23 requires the IDE bus switches enabled (jumper J-IDE set). No stubs are allowed on an IDE cable assembly, i.e. concurrent operation of devices attached to P23 and other IDE dedicated connectors cannot be guaranteed.

P23 External IDE Device 2.54mm Dual Row Pin Header				
	ide1_reset#	1	2	GND
	ide1_dd07	3	4	ide1_dd08
	ide1_dd06	5	6	ide1_dd09
	ide1_dd05	7	8	ide1_dd10
	ide1_dd04	9	10	ide1_dd11
	ide1_dd03	11	12	ide1_dd12
	ide1_dd02	13	14	ide1_dd13
	ide1_dd01	15	16	ide1_dd14
	ide1_dd00	17	18	ide1_dd15
	GND	19	20	KEY
	ide1_dmarq	21	22	GND
	ide1_diow#	23	24	GND
	ide1_dior#	25	26	GND
	ide1_iordy	27	28	GND
	ide1_dmack#	29	30	GND
	ide1_intrq	31	32	NC
	ide1_a1	33	34	ide1_cblid#
	ide1_a0	35	36	ide1_da2
	ide1_cs1#	37	38	ide1_cs3#
	ide0_act#	39	40	GND

P24 IDE/ATA Connector for 2.5-Inch Drives

P24 is optionally provided for a 2.5-inch on-board hard disk drive. Usage of P24 requires the IDE bus switches enabled (jumper J-IDE set). No stubs are allowed on an IDE cable assembly, i.e. concurrent operation of devices attached to P24 and other IDE dedicated connectors cannot be guaranteed.

P24 On-Board 2.5-Inch Hard Disk Drive 2.00mm Pin Header 2x22

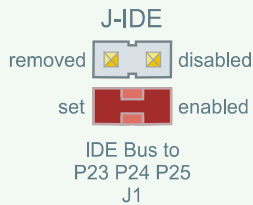
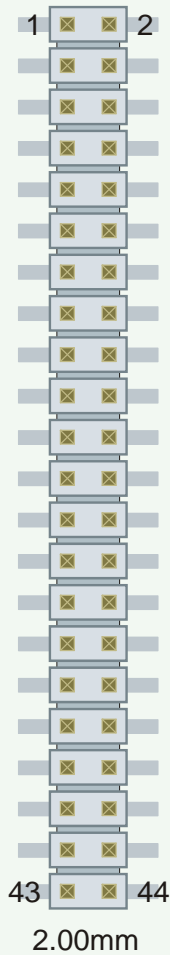

ide1_reset#	1	2	GND
ide1_dd07	3	4	ide1_dd08
ide1_dd06	5	6	ide1_dd09
ide1_dd05	7	8	ide1_dd10
ide1_dd04	9	10	ide1_dd11
ide1_dd03	11	12	ide1_dd12
ide1_dd02	13	14	ide1_dd13
ide1_dd01	15	16	ide1_dd14
ide1_dd00	17	18	ide1_dd15
GND	19	20	KEY
ide1_dmarq	21	22	GND
ide1_diow#	23	24	GND
ide1_dior#	25	26	GND
ide1_iordy	27	28	GND
ide1_dmack#	29	30	GND
ide1_intrq	31	32	NC
ide1_da1	33	34	ide1_cblid#
ide1_da0	35	36	ide1_da2
ide1_cs1#	37	38	ide1_cs3#
ide0_act#	39	40	GND
+5V_HD	41	42	+5V_HD
GND	43	44	NC

P30 LAN Connect I/F (LCI) Connector

As an option, the CCB-BOSSANOVA is equipped with a Platform LAN Connect (PLC) 10/100Mbps Fast Ethernet controller. This component communicates with the host CPU board through the LAN Connect I/F (LCI), which is a peripheral port on the ICH4. The LCI is available from connector P30. It is a socket such as P1 and P21, located typically on both sides of the CCB-BOSSANOVA for top or bottom mounting.

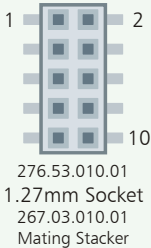
P30T(B) 276.53.010.01				
	GND	1	2	lci_clk
	lci_rxd1	3	4	GND
	lci_rxd2	5	6	lci_rxd0
	lci_rst	7	8	lci_txd2
	lci_txd1	9	10	lci_txd0

The CCB-BOSSANOVA itself does not provide an EEPROM containing the MAC address of the secondary Ethernet port, since the 82562 PLC controller is mainly a PHY. Instead, the MAC function is integrated into the ICH4 on the CC9-SAMBA. So usage of the secondary Ethernet port requires the respective EEPROM on the host CPU board to be present and programmed adequately. The LCI interface is solely available on the CC9-SAMBA, but not on the CCD-CALYPSO nor on the CD3-JIVE CPU carrier boards.

J1/J2 Rear I/O

As an option, the CCB-BOSSANOVA can be equipped with the rear I/O connectors J1 and J2. A single slot rear I/O backplane (directly adjoining the CPCI backplane) would be required for handing over the available signal lines to a suitable rear I/O transition module.

The CCB-BOSSANOVA must not be plugged into a common CPCI slot in order to avoid damaging the board or other components of the system. A brown key on the J1 connector will prevent the user from erroneously inserting the CCB-BOSSANOVA into an unsuitable position.

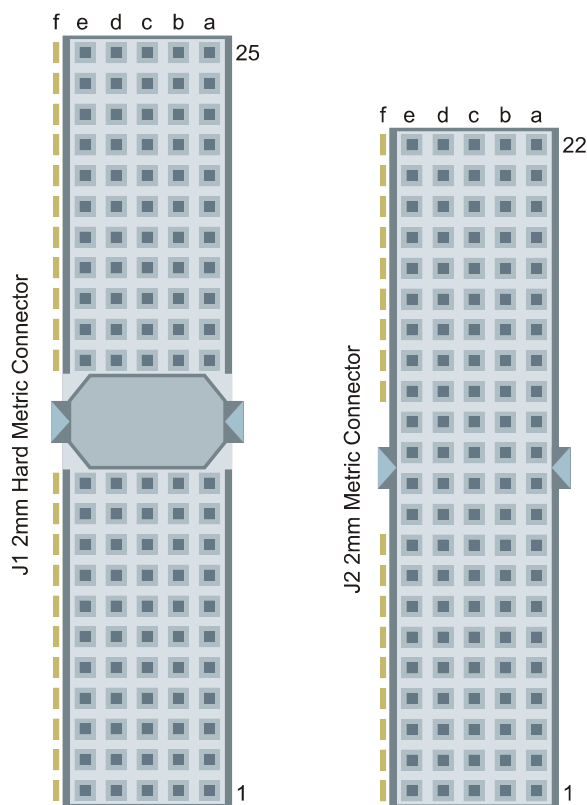

Signal names provided on the J1 and J2 connector tables hereafter are associated with their main function. However, the Super I/O controller allows a number of signals also be used as general purpose I/O. Please consult the SMSC LPC47B27x datasheet for details (www.smsc.com).

Please note, that the majority of signals is also available on-board or via front panel. Be sure to have connected any signal only once, in order to avoid interference.

With respect to the IDE/ATA interface, the jumper J-IDE (if provided) must be set, in order to enable rear I/O mass storage attachment. No stubs are allowed on an IDE cable assembly, i.e. concurrent operation of devices attached to J1 and other IDE dedicated connectors cannot be guaranteed.

J1 Rear I/O Connector

#J1	A	B	C	D	E
25	+5V	USB5_d+	USB5_d-	+3.3V	+5V
24	IDE_d08	+5V	+5V_USB5 VI/O	IDE_reset#	IDE_d07
23	+3.3V	IDE_d09	IDE_d10	+5V	IDE_d06
22	IDE_d11	GND	+3.3V	IDE_d04	IDE_d05
21	+3.3V	IDE_d12	IDE_d13	M66EN (GND)	IDE_d03
20	IDE_d14	GND	VI/O	IDE_d01	IDE_d02
19	+3.3V	IDE_d15	IDE_dmarq	GND	IDE_d00
18	IDE_dmack#	GND	+3.3V	IDE_ior#	IDE_iow#
17	+3.3V	IDE_a1	IDE_cblid#	GND	IDE_iordy
16	IDE_a2	GND	VI/O	IDE_a0	IDE_intrq
15	+3.3V	IDE_cs1#	IDE_act#	GND	IDE_cs0#
14					
13			KEY (BROWN)		
12					
11				GND	KB_dat
10		GND	+3.3V		KB_clk
9				GND	MS_dat
8		GND	VI/O		MS_clk
7				GND	+5V_PS2
6		GND	+3.3V	GP11	GP12
5				GND	
4	dbreset#	GND	VI/O	GP16	GP17
3	GAME_but21	GAME_but22	GAME_joy2x	+5V	GAME_joy2y
2	GAME_but11	+5V	GAME_but12	GAME_joy1x	GAME_joy1y
1	+5V	-12V	keylock#	+12V	+5V

pin positions coloured gray: not connected

J2 Rear I/O Connector

#J2	A	B	C	D	E
22	GPIO21	GPIO22	GPIO43	GPIO60	GPIO61
21	COM-A_ri	GND	COM-B_ri	COM-B_cts	FD_drvden0#
20	COM-A_cts	GND	COM-B_rxd	GND	FD_drvden1#
19	GND	GND	COM-B_dsr	COM-B_dcd	FD_index#
18	COM-A_rxd	COM-A_dsr	COM-B_dtr	GND	FD_mtr0#
17	COM-A_dcd	GND	COM-B_rts	COM-B_txd	FD_ds0#
16	COM-A_dtr	COM-A_rts	SER2_ri	GND	FD_dir#
15	COM-A_txd	GND	SER2_cts	SER2_rxd	FD_step#
14	SER1_ri	SER1_cts	SER2_dsr	GND	FD_wdata#
13	SER1_rxd	GND	V(I/O)	SER2_dcd	FD_wgate#
12	SER1_dsr	SER1_dcd	SER2_dtr	GND	FD_trk0#
11	SER1_dtr	GND	V(I/O)	SER2_rts	FD_wrtprt#
10	SER1_rts	SER1_txd	SER2_txd	GND	FD_rdata#
9	SER1_shdn	GND	V(I/O)	SER2_shdn	FD_hdsel#
8	LPT_slct	LPT_pe	LPT_busy	GND	FD_dskchg#
7	LPT_ack#	GND	V(I/O)	USB6_d+	USB6_d-
6	LPT_d7	LPT_d6	LPT_d5	GND	+5V_USB6
5	LPT_d4	GND	V(I/O)	MIDI_out	MIDI_in
4	V(I/O)	LPT_d3	LPT_slctin#	GND	speaker
3	LPT_d2	GND	LPT_init#	IRDA_tx	IRDA_rx
2	LPT_d1	LPT_error#	LPT_d0	FAN_tach2	FAN_tach1
1	LPT_alf#	GND	LPT_strobe#	FAN_pwm2	FAN_pwm1

pin positions coloured gray: not connected

RS-232E Transceivers

The Super-I/O chip provides two asynchronous serial ports (TTL level), which are passed via the J2 rear I/O connector to a rear I/O transition module (option).

Furthermore, the CCB-BOSSANOVA is optionally provided with two serial transceivers according to RS-232E. As with the TTL level serial port signals, also the RS-232 transmission lines are wired to the J2 rear I/O connector for usage on a transition module (back panel COM port connectors). Each transceiver can be individually disabled by the jumpers J-SER1 and J-SER2, if either the particular RS-232 interface is not at all required (with a power saving effect), or if a different interface type is required, e.g. EIA/TIA-485 or optically isolated RS-232 (physical transceivers attached to the TTL level signals, located either on the rear I/O transition module, or attached to P13/P16).

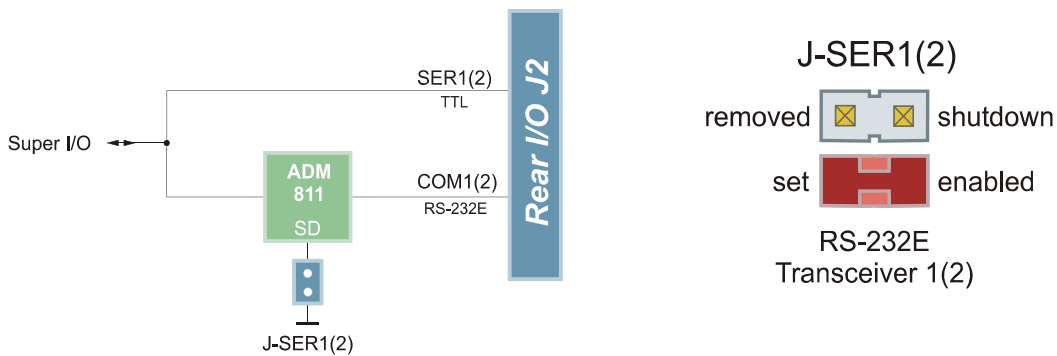

Conclusion: Each on-board transceiver on the CCB-BOSSANOVA must be enabled by setting its associated jumper J-SERx in order to use the COMx rear panel connector(s). If however the serial TTL lines are needed for a special interface solution, the particular on-board transceiver(s) must be disabled by removing its jumper J-SERx.



CU-Series PHY Module

Firmware Hub 2

The CCB-BOSSANOVA is optionally provided with a 82802 compatible 8Mbit Flash (Firmware Hub), which can be used either as alternative boot BIOS, as an expansion memory to the CPU board BIOS, or for BIOS retrieval/rescue. The Firmware Hub is connected to the LPC (Low Pin Count) interface. The device ID of a particular FWH determines whether it is detected as BIOS after power on (ID = 0). If stuffed, the jumper J-FWH sets the on-board FWH2 ID to zero (and simultaneously changes the CC9-SAMBA FWH ID to 1) - hence the system will use the BIOS on the CCB-BOSSANOVA after power-on.

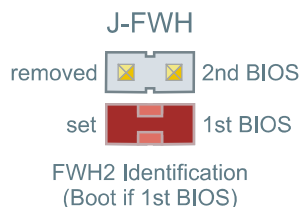

A programming tool for the Firmware Hub and latest BIOS releases can be obtained from the EKF website.

Power Supply Requirements

Operating Voltage	max. Current
+5V / $\pm 0.25V$	TBD
+3.3V / $\pm 0.1V$	TBD
+12V / $\pm 0.5V$	TBD

Schematics

Complete circuit diagrams for this product are available for customers on request. Signing of a non-disclosure agreement would be needed. Please contact sales@ekf.de for details.

EKF reserves the right to refuse distribution of confidential information material for any reason that EKF may consider substantial.

boards.

systems.

solutions.

EKF Elektronik GmbH
Philipp-Reis-Str. 4
59065 Hamm
Germany



Phone +49 (0)2381/6890-0
Fax +49 (0)2381/6890-90
Internet www.ekf.com
E-Mail info@ekf.com